



Notice de montage

à lire **IMPÉRATIVEMENT**

avant de démarrer l'assemblage



Vidéo de montage sur :
www.porte-en-kit.fr

Détail pièces montage porte

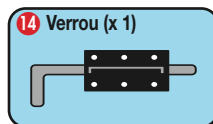
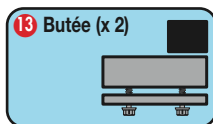
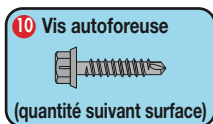
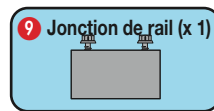
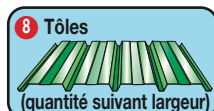
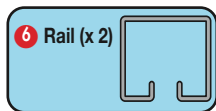
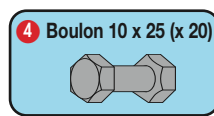
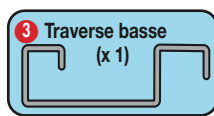
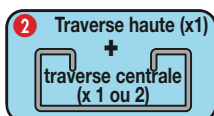
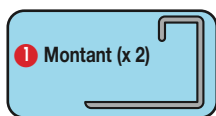

Détail pièces montage rail

- Simple rail sur charpentepage 4
- Simple rail sur murpage 6
- Double railpage 7

1

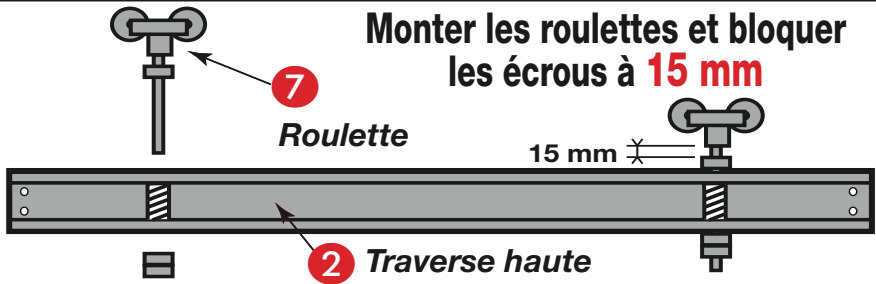

2

Assembler le cadre au sol, **sans bloquer les boulons**

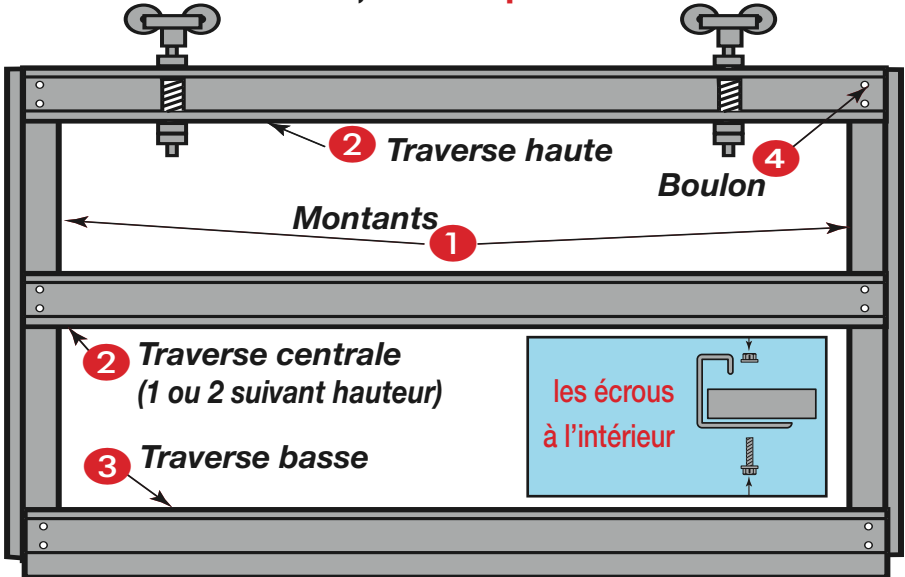

3

Régler le cadre pour obtenir les **diagonales de longueurs identiques** puis bloquer les boulons

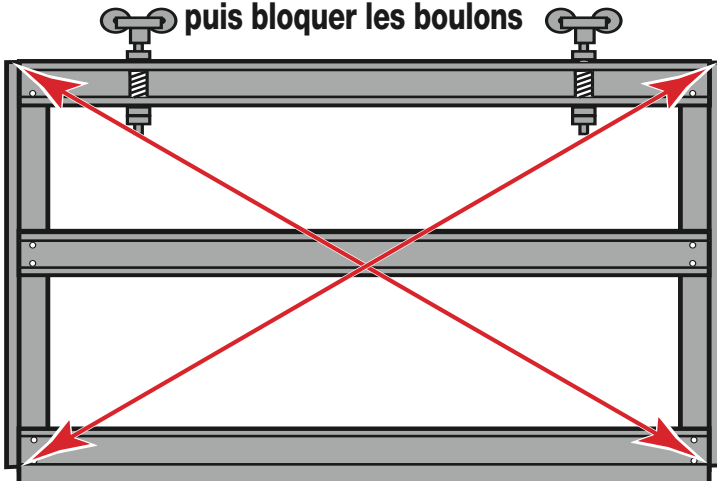

4

 **Attention** : Placer les tôles sur le cadre.
Puis les centrer par rapport aux traverses basse et haute.

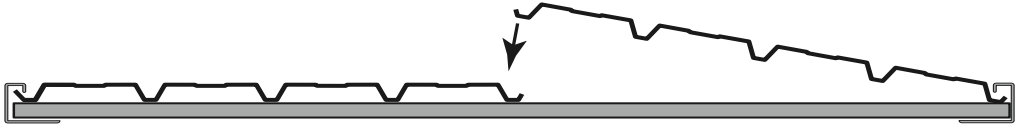

5

Visser les vis autoforeuses dans chaque creux d'onde sur les 3 traverses

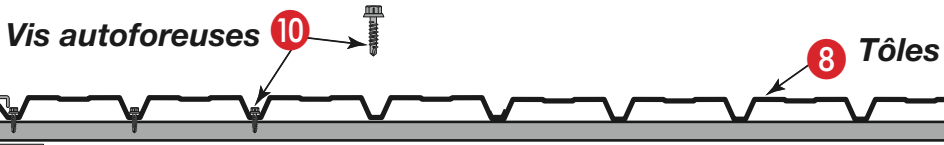

 **Conseil** : Retirer systématiquement toutes particules métalliques, copeaux ou limailles car ils peuvent oxyder le revêtement.

Pour ne pas abîmer les tôles, poser la tôle de protection de l'emballage et le feutre sur la porte afin d'effectuer le vissage des vis autoforeuses sur la ou les traverse(s) centrale(s).

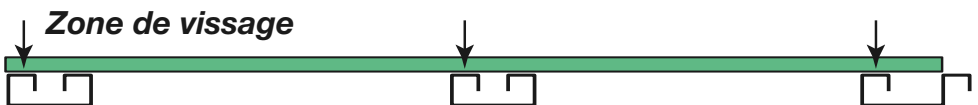

6

Reportez-vous aux notices de montage rail pages 4 à 8 suivant le modèle choisi puis reprendre le montage page 9.

Notice de montage **SIMPLE RAIL** sur **CHARPENTE**

11 Pied de porte (x 1)



ou

Jonction porte double
(1 pour 2 portes)

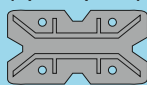

12 Guide bas de porte
(x 1)



15 Profil UPN 140
(x 2)



16 Support rail
(Qté A *)

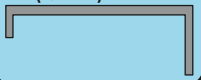

17 Boulon M10 x 25
(Qté B *)

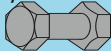

18 Boulon M 16 x 50
(x 8)

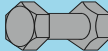

* Largeur Porte (en m)

	3,06	4,06	5,06	6,06
Qté A	12	16	20	24
Qté B	24	32	40	48

7 Assembler les profils U, les supports de rail et les rails au sol

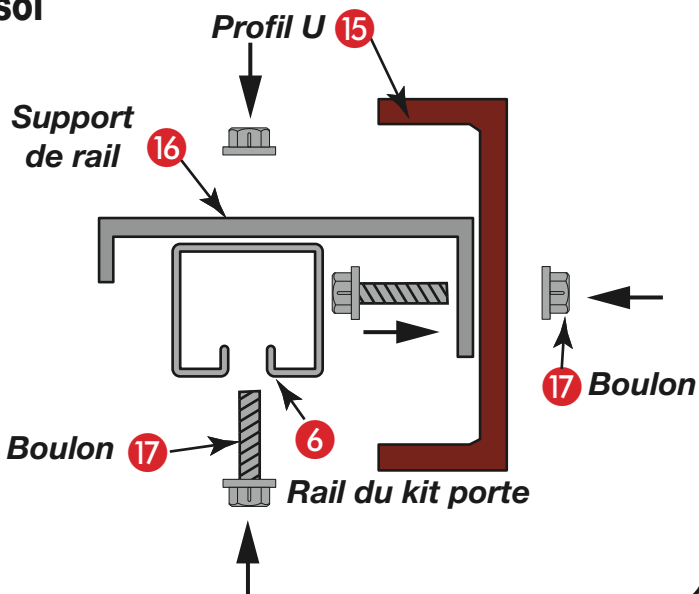

8 Fixer les ensembles aux poteaux

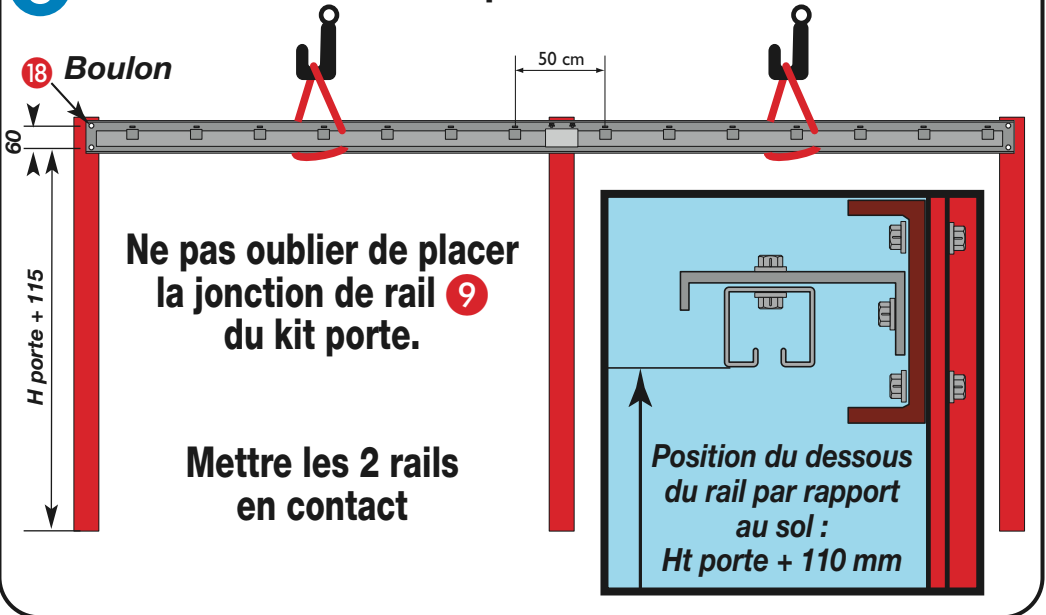

9 Mise en place du larmier

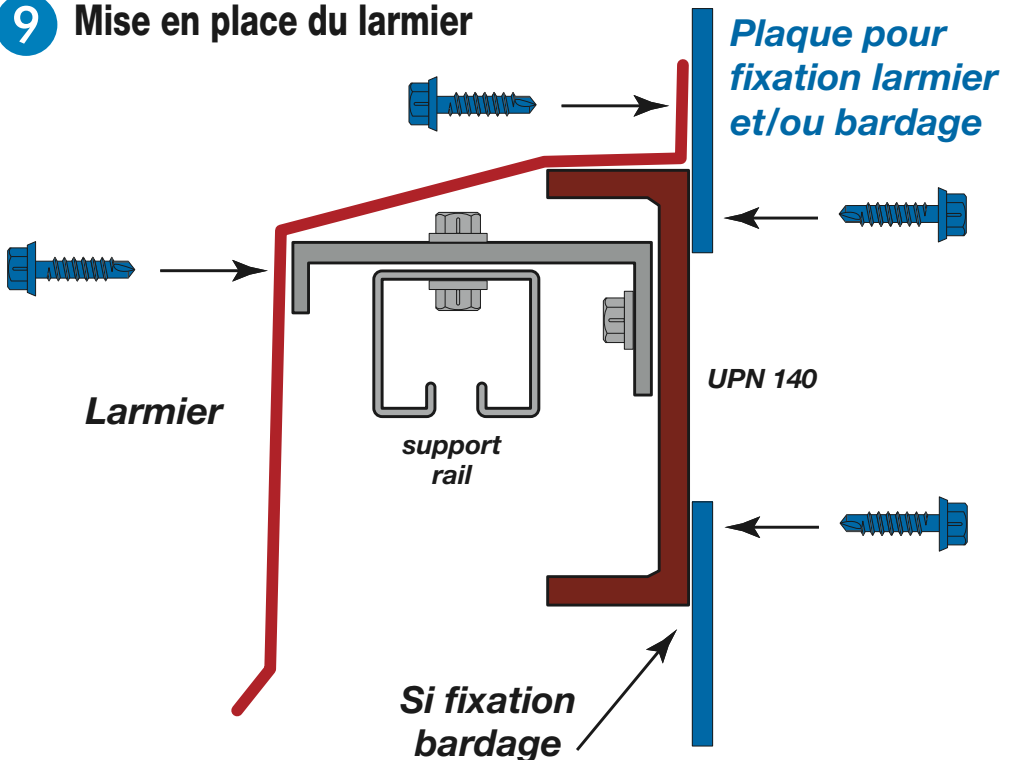

Notice de montage **SIMPLE RAIL** sur **MUR**

11 Pied de porte (x 1)



ou

Jonction porte double
(1 pour 2 portes)

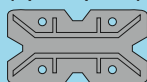

12 Guide bas de porte
(x 1)



19 Equerre

(Qté *)



ATTENTION
Chevilles
non fournies

20 Support
enveloppant
(Qté *)



* Largeur Porte (en m)

	3,06	4,06	5,06	6,06
Qté	12	16	20	24

10 Fixer les équerres au mur

Attention :
adapter les fixations
au spécificité
du support

Support
enveloppant

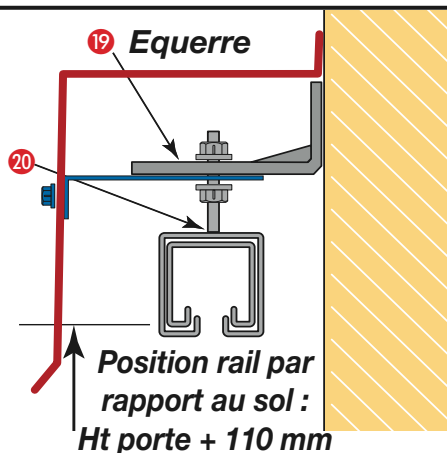

11 Répartir les supports tous les 50 cm

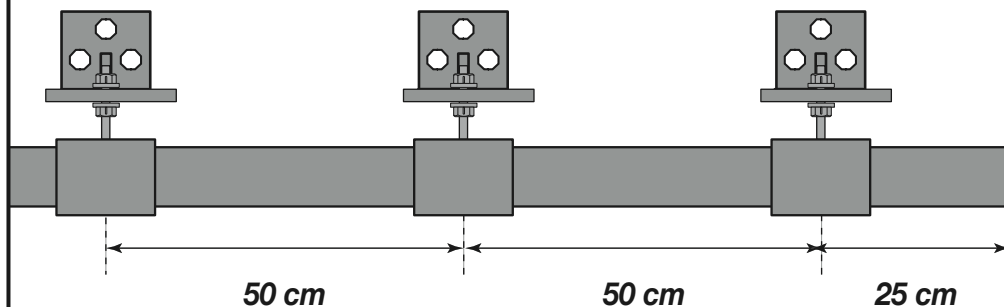

Départ à 25 cm par rapport
à l'extrémité du rail

Notice de montage **DOUBLE RAIL** sur **CHARPENTE**

21 Profil UPN 160
(x 1)

22 Support rail
externe (Qté B *)

18 Boulon M 16 x 50
(x 8)

23 Boulon M10 x 30
(Qté A *)

25 Support UPN (x 2)

24 Support rail
interne (Qté B *)

11 Jonction
porte double (x 3)

* Largeur Porte (en m)

	3,06	4,06	5,06	6,06
Qté A	18	24	30	36
Qté B	6	8	10	12

26 Guide porte sol
à sceller (x 2)

12 Assembler le profil U,
les supports de rail et les
rails au sol

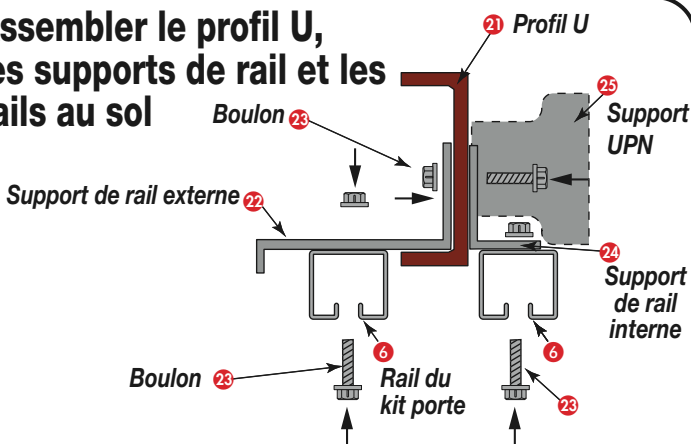

13 Assembler les supports UPN **25** aux poteaux

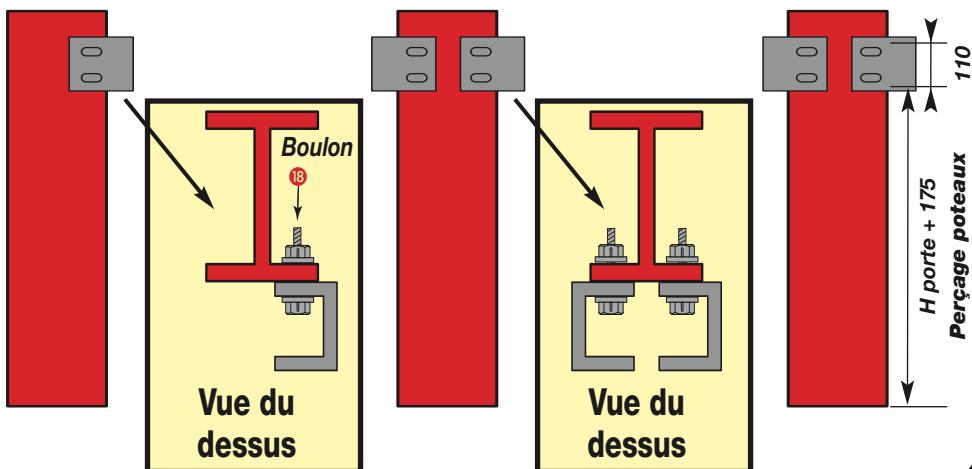

14 Assembler les ensembles montés en 1 au support UPN

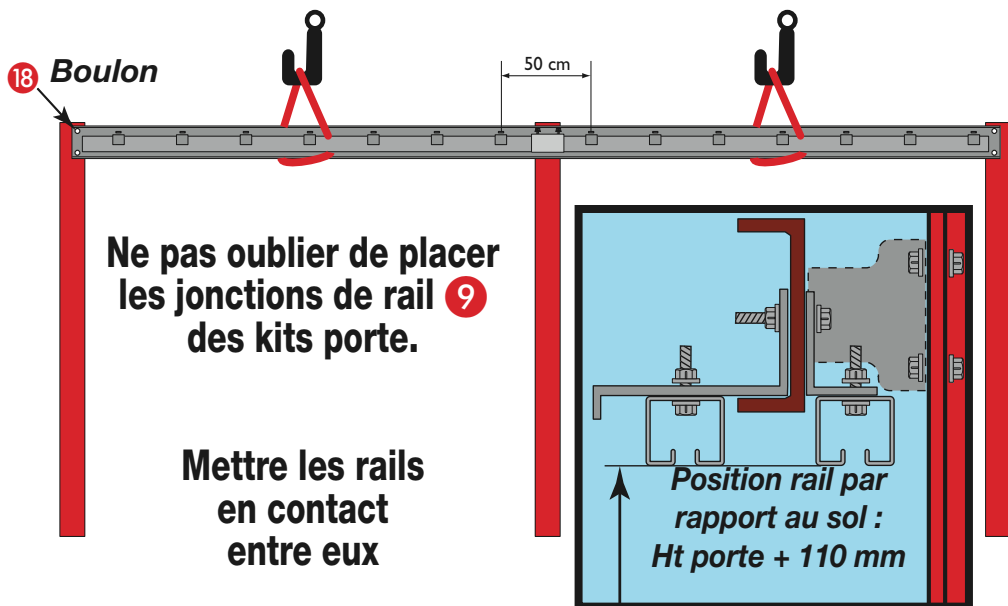

15 Mise en place du larmier

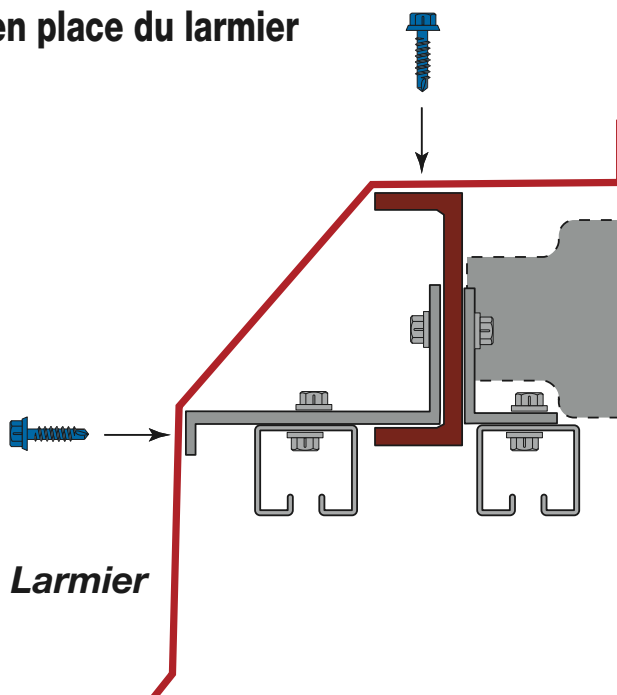

16 Mettre en place la porte dans le rail

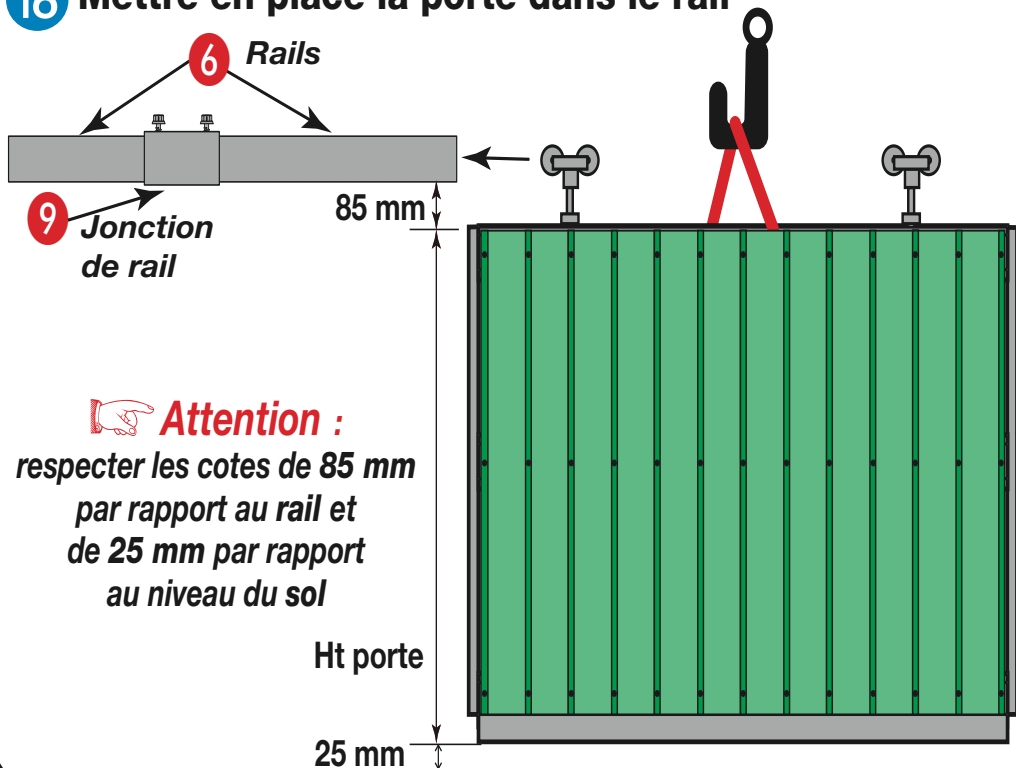

17 Insérer les butées puis les bloquer

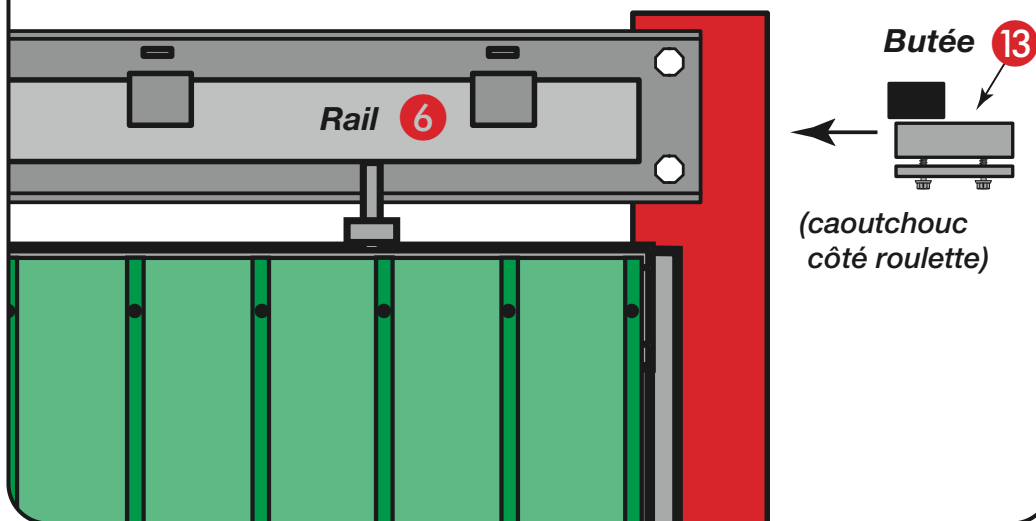

 **Attention** : uniquement pour porte sur **SIMPLE** rail

18 Mise en place du guide bas de porte **12** et pied de porte **11**
(fixation par boulon ou par soudure, **en respectant la hauteur de 10 mm par rapport au sol**)

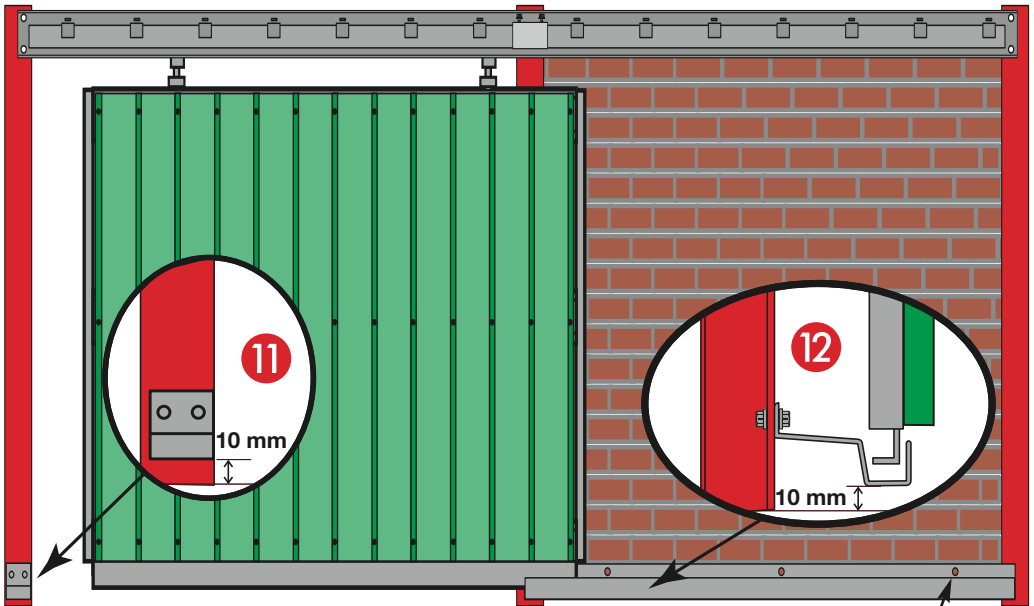

 **Attention** : chevilles à poser **NON** fournies

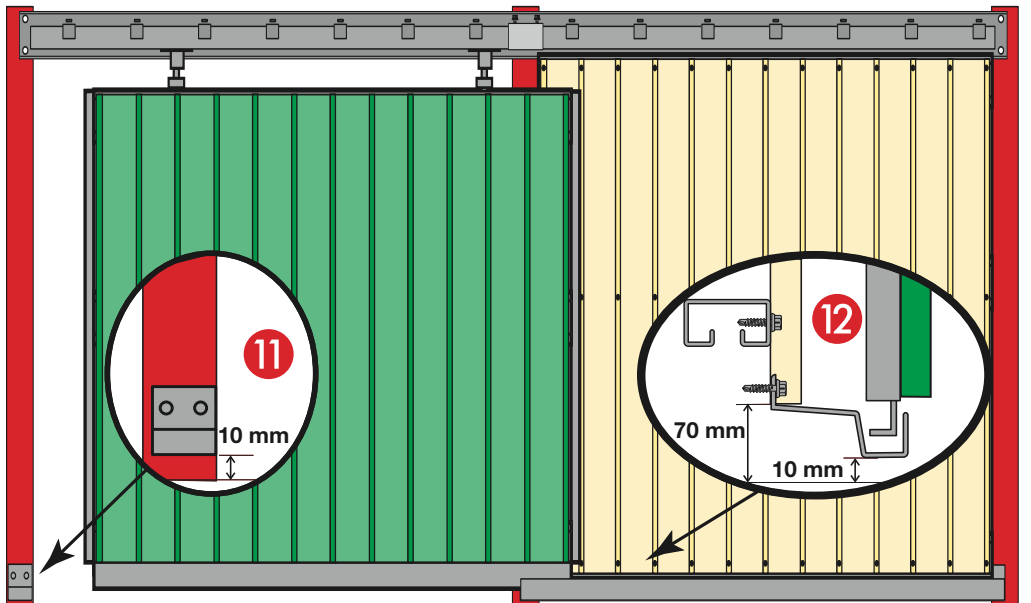

 **Attention** : uniquement pour porte sur **SIMPLE** rail

19 Option porte double sur simple rail

13 *Butées réglées pour avoir les portes jointives*

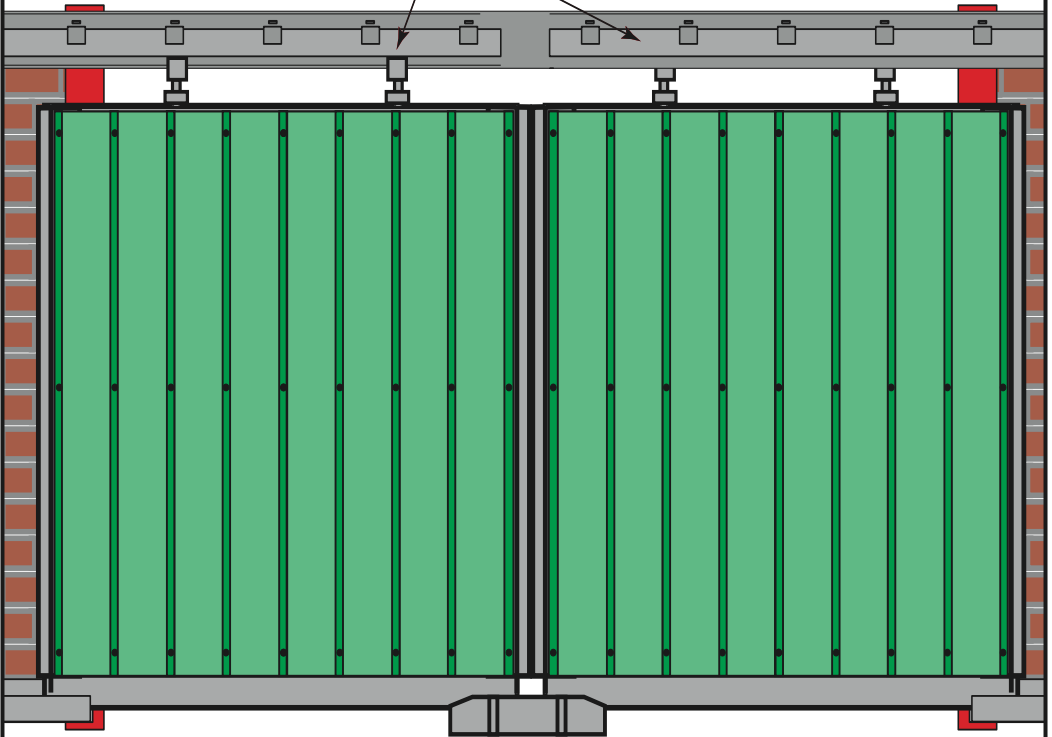

Jonction de porte double fixée au sol

 **Attention** : chevilles non fournies

20 Pour régler la hauteur du verrou, verrouiller la porte en position ouverte puis fixer à l'aide des vis autoforeuses **10**

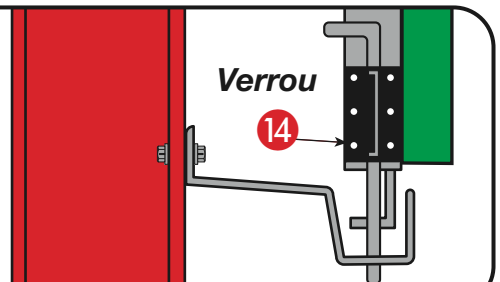

 **Attention** : uniquement pour porte sur **DOUBLE** rail

21 Mise en place des guides bas de porte à sceller **22** et à cheiller **23**

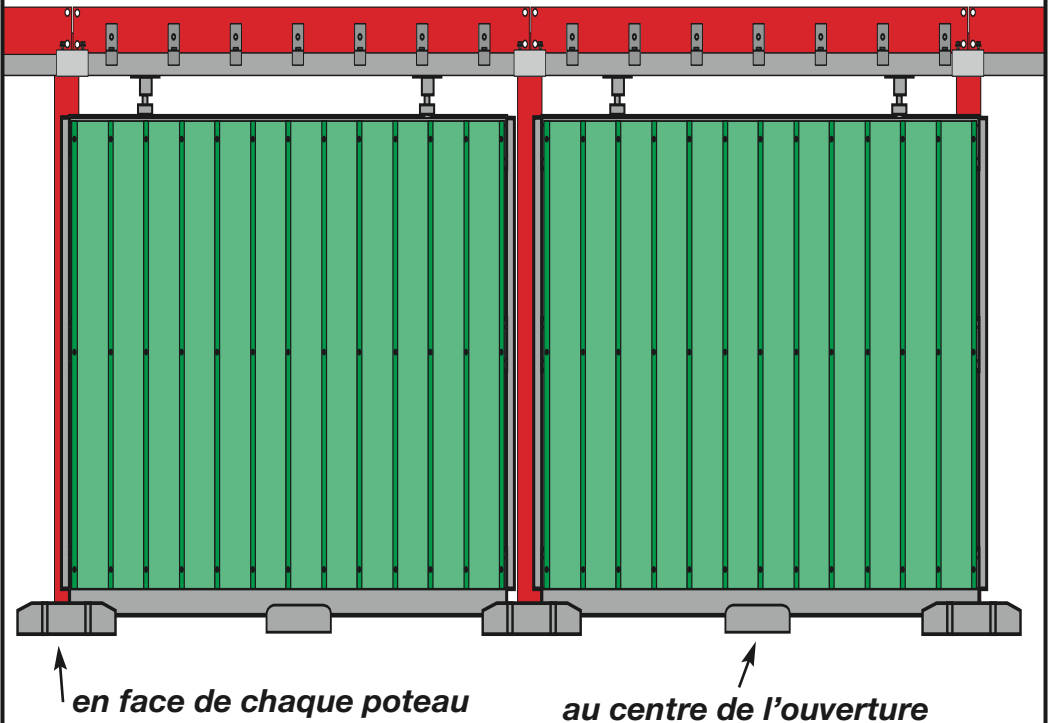

 **Attention** : chevilles à poser **NON** fournies)

22 Pour régler la hauteur du verrou, verrouiller la porte en position fermée puis fixer à l'aide des vis autoforeuses **10**

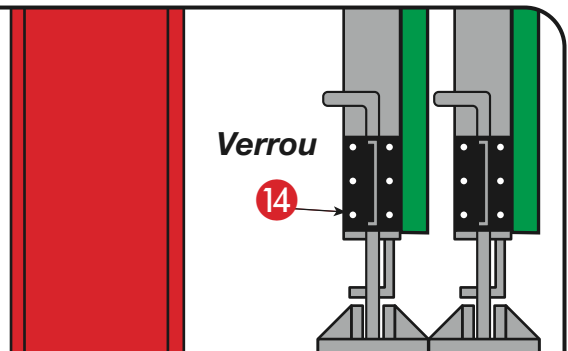

Précautions de montage : Montage à réaliser par des personnes compétentes.

Utiliser les protections individuelles nécessaires.

Références habillage pour porte en kit sur charpente

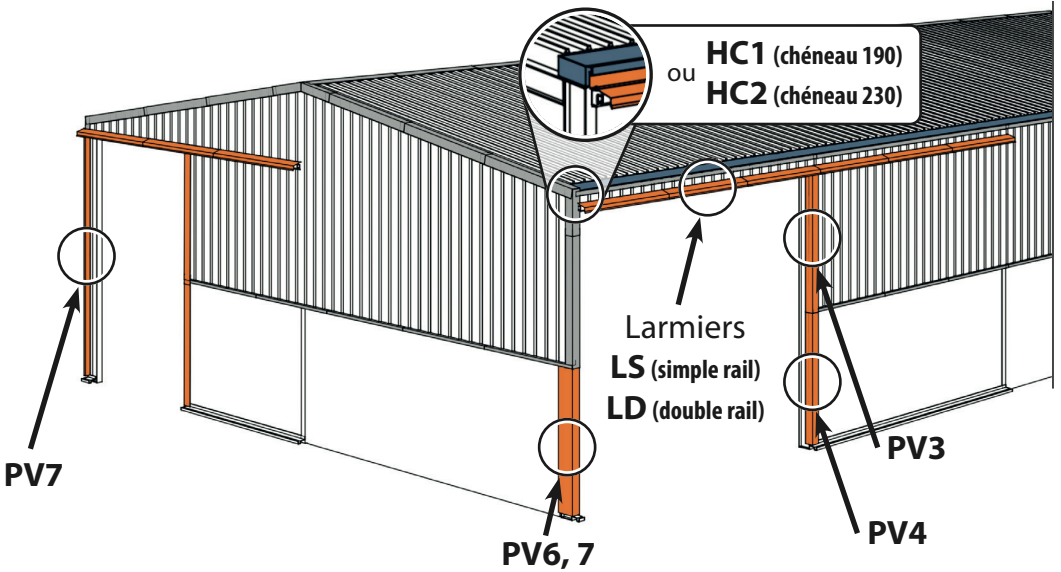

Références habillage pour porte en kit sur mur

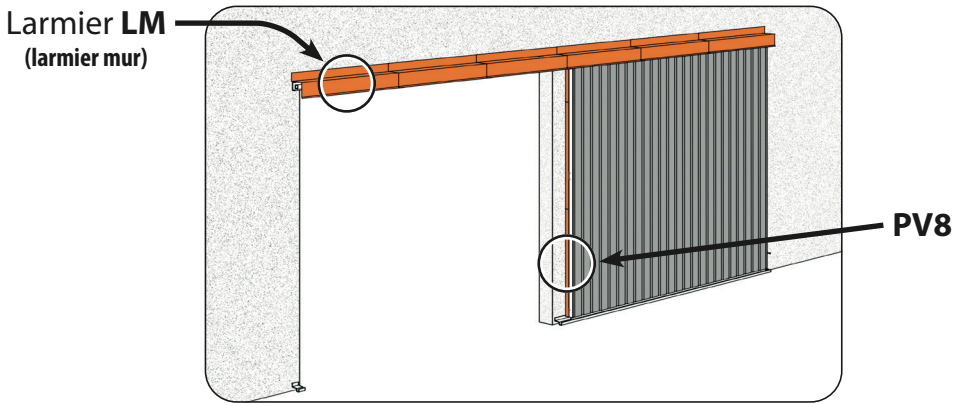

Références habillage pour porte en kit double rail

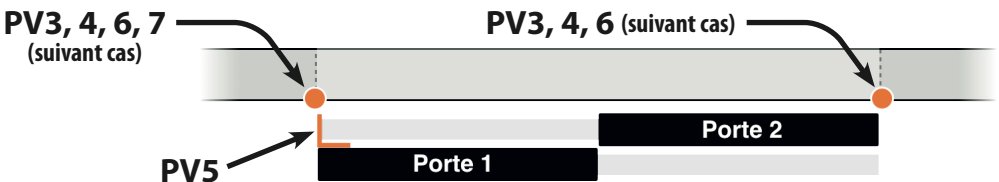

CAS 1

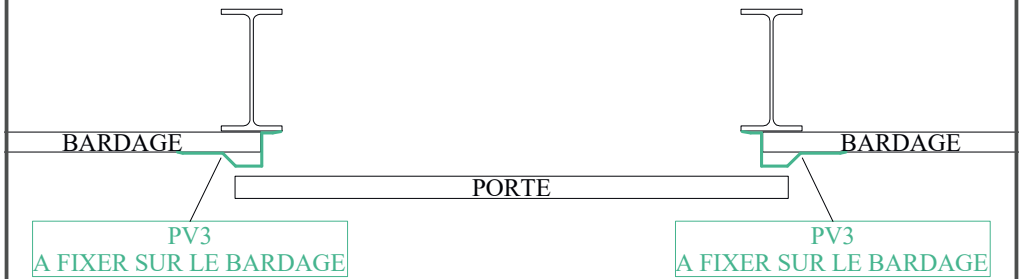

CAS 2

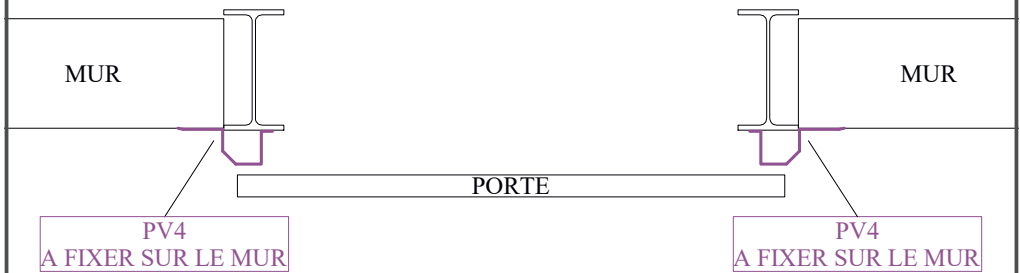

CAS 3

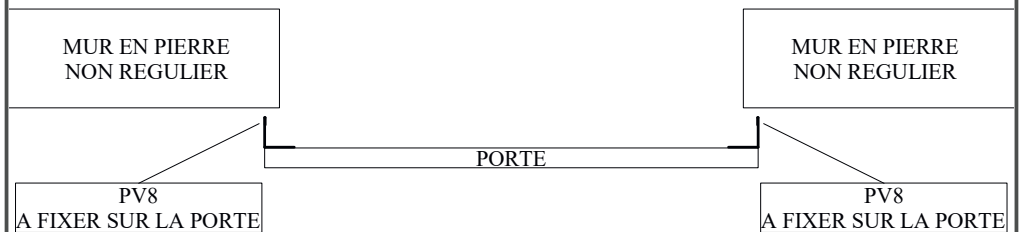

CAS 4

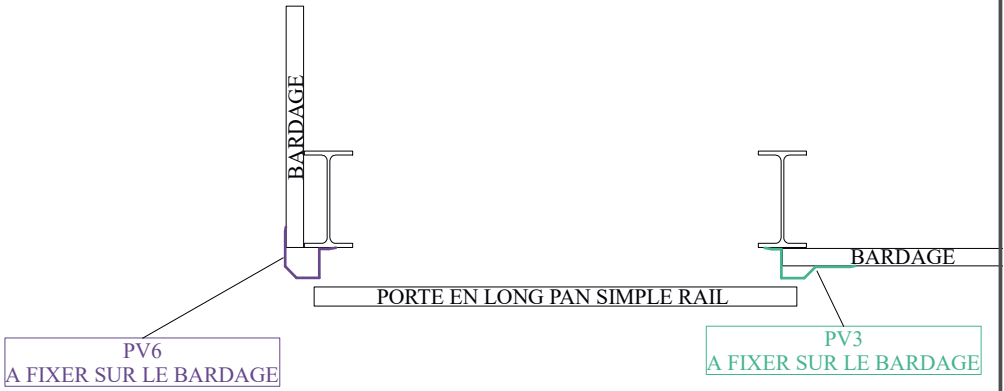

CAS 5

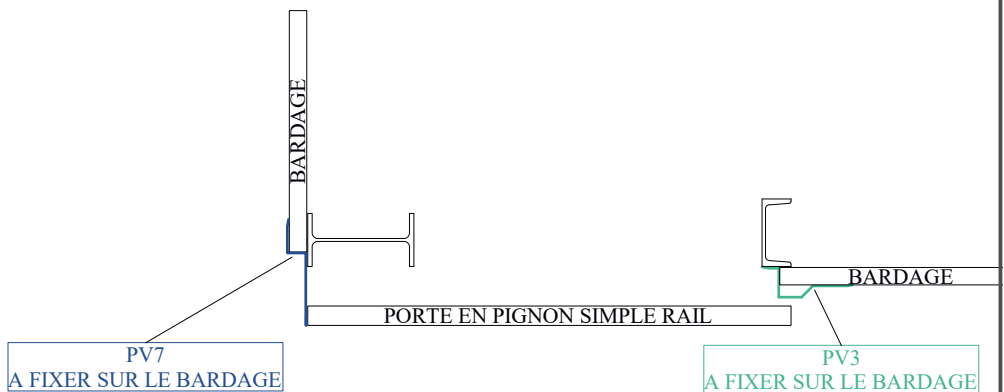

CAS 6

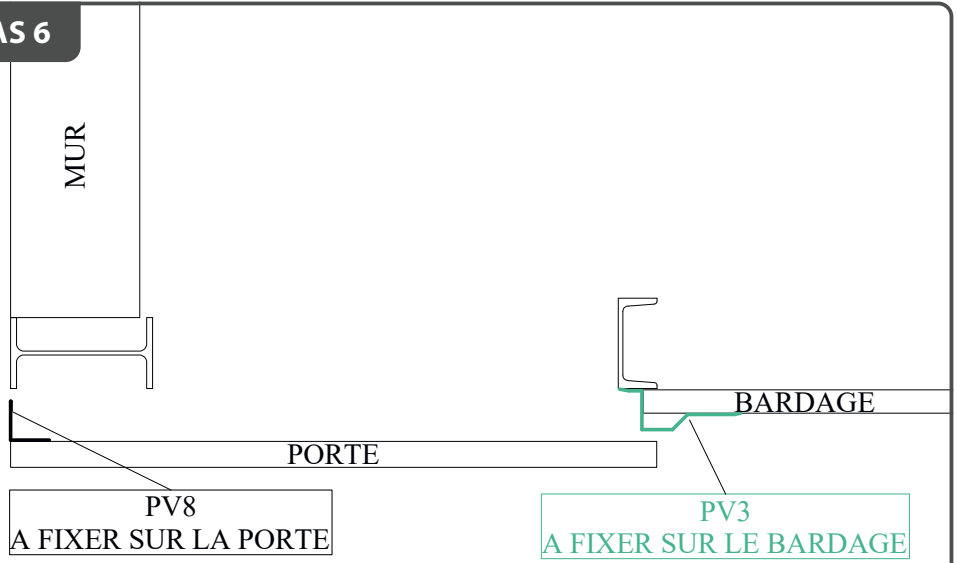

CAS 7

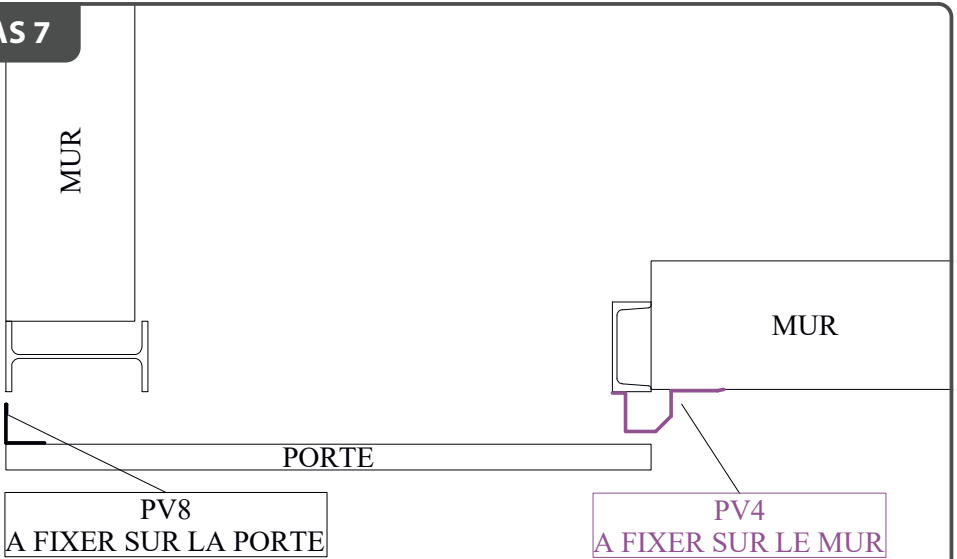

CAS 8

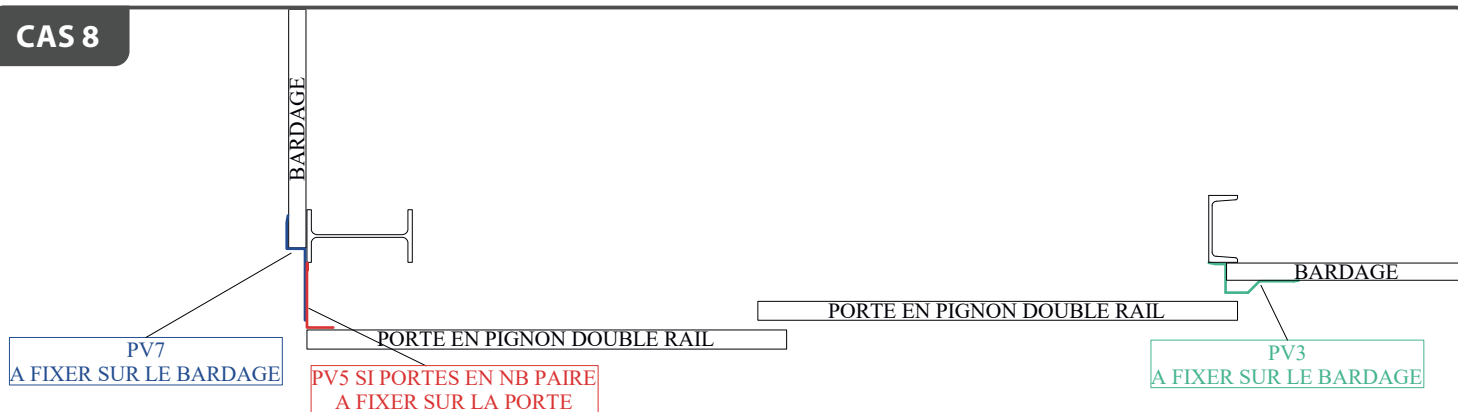

CAS 9

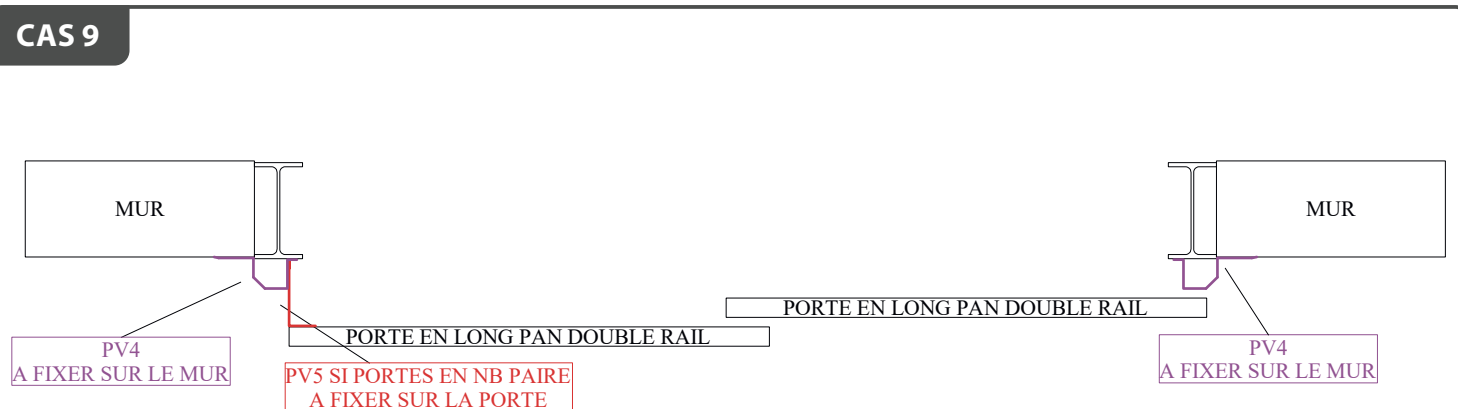

CAS 10

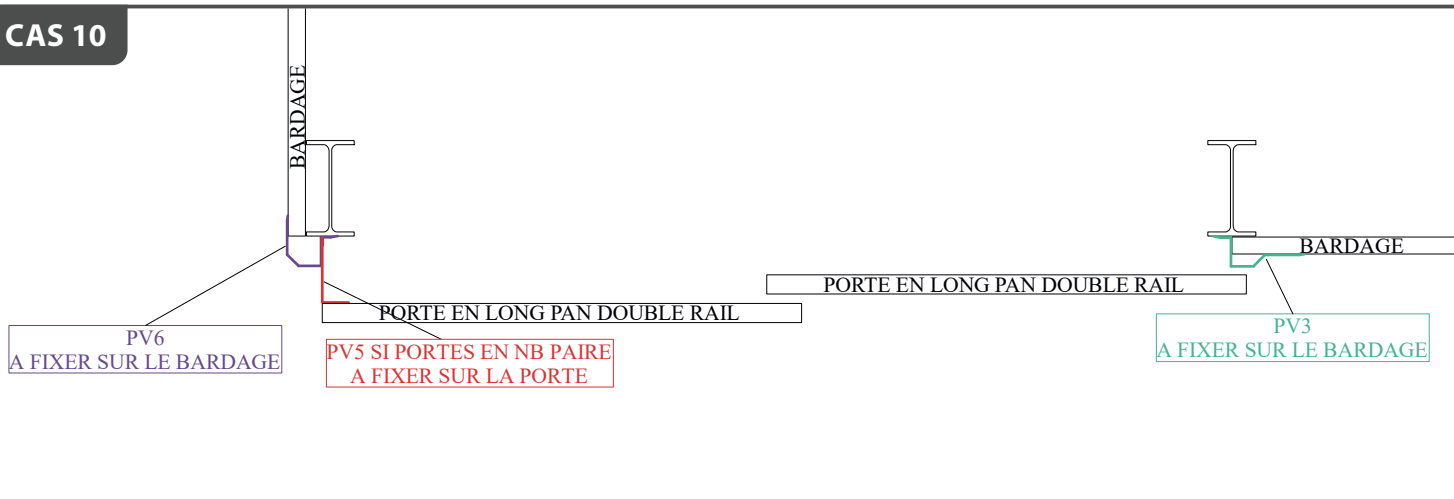

CAS 11

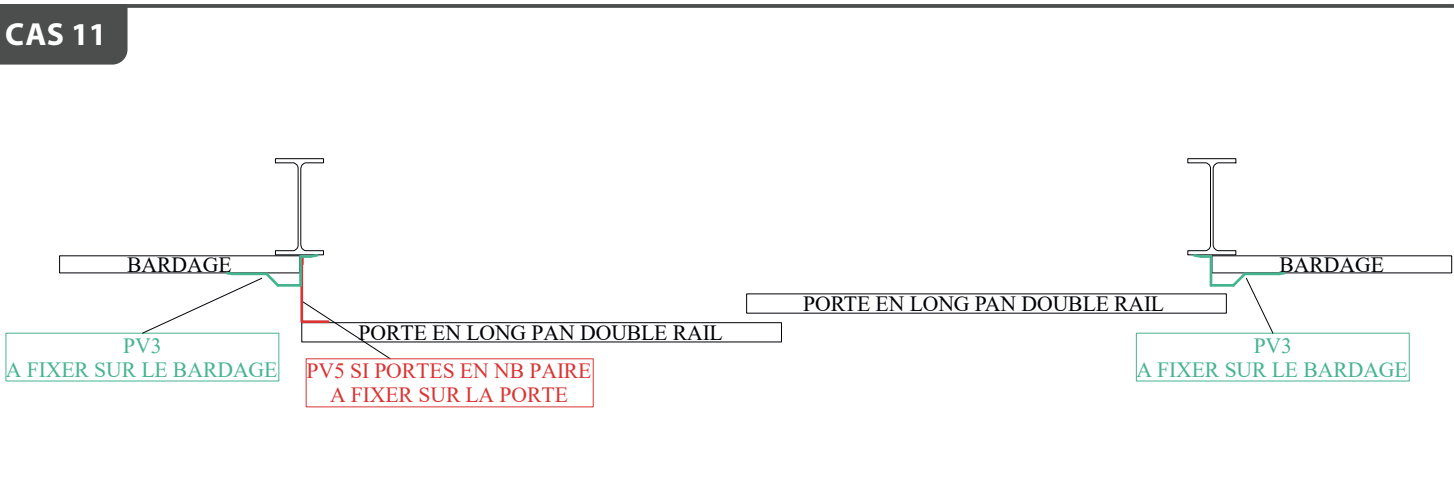

MONTAGE HABILLAGE LINTEAU/CHÉNEAU SUR SIMPLE RAIL

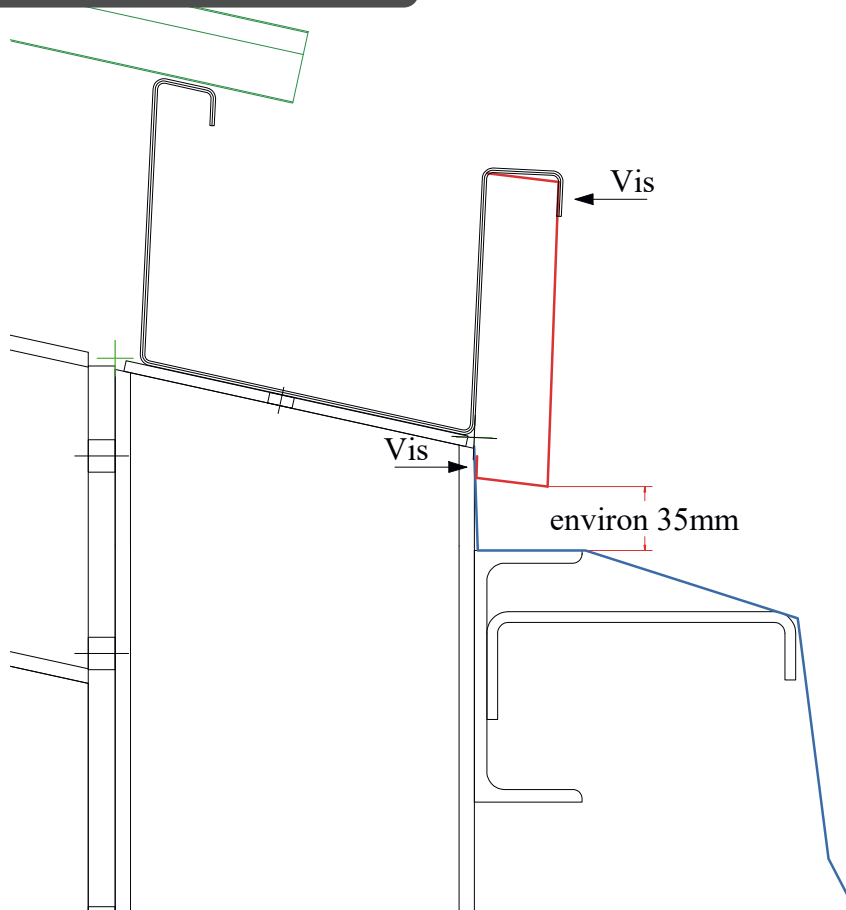

MONTAGE HABILLAGE LINTEAU/CHÉNEAU SUR DOUBLE RAIL

